

1	M8*14 Hexagonsocket cup head screws	4
2	Foot	2
3	Column	2
4	ST4.8*20 wood screw	9
5	Side Bracket	1
6	M6*14 Machine screw	2
7	ST4.8*20 wood screw	4
8	M6*10 Hexagonsocket cup head screws	8
9	Frame 1	1
10	Cable Clip (Insert the frame)	4
11	Control Box	1
12	Center Rail	2
13	M6*10 machine screw	8
14	Frame 2	1
15	Power cord (3m)	1
16	Connecting cable (1m)	2

Lift capacity 125 kg evenly



**Easy to Go**  
UPEA2372



**SCAN SØRLIE**  
NEW NORDIC DESIGN

**SCAN SØRLIE**  
NEW NORDIC DESIGN

**STEP 1: Easy-to-open box**

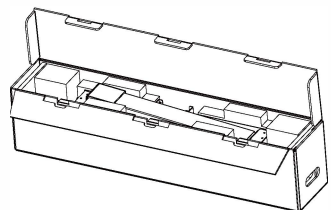

**STEP 2: Rise into position**

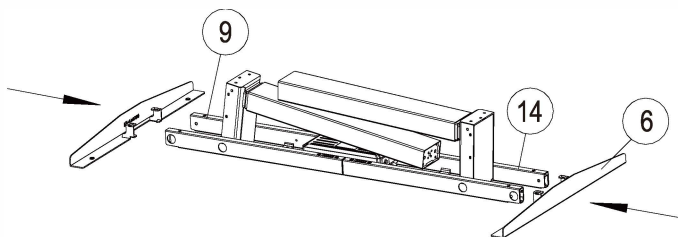

**STEP 3: Fasten with 4 screws**

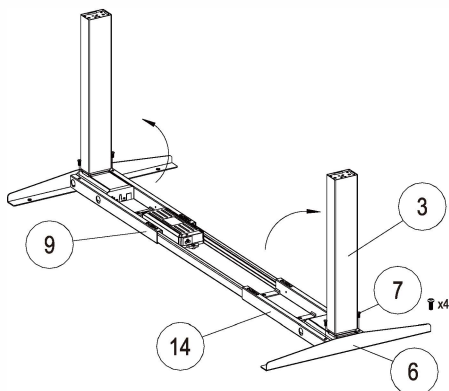

**STEP 4: Assemble feet with 4 screws**

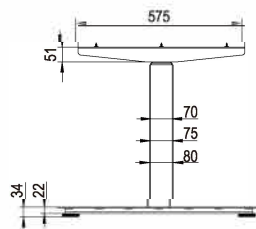
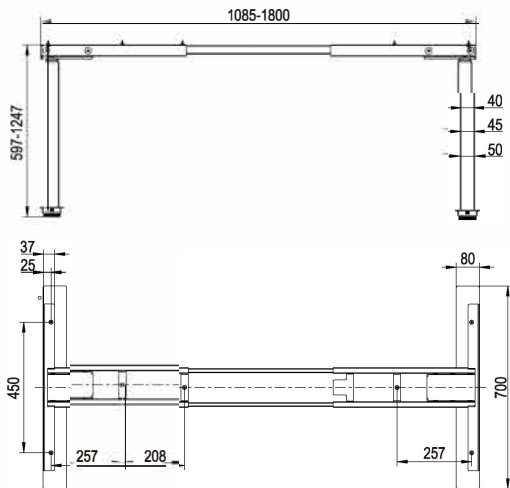
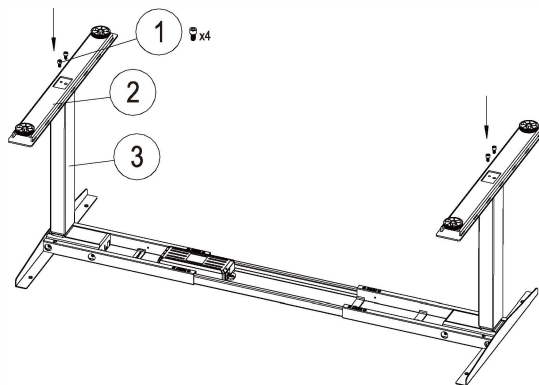

Lift capacity: 2-leg/ 3-leg :125 kg

**SCAN SØRLIE**  
NEW NORDIC DESIGN

**Key Features:**

- "Easy to go" package
- Small package size (1086x211x252) / Package weight approx. 33 kg / Low noise under 45 dB
- Adjustable frame (1080-1800 mm.)
- Build-in cable clips for cable management
- Easy assemble (Approx 4-5 min. pr. Desk)
- Build-in sensor anti collision



Control box & Control:  
Standard Control BOX



Standard Control for package  
With LED function

**Packaging:**  
Single packed - size 1086x211x252



Single packed and strapped

**SCAN SØRLIE**  
NEW NORDIC DESIGN

**Manual**  
Last ned fra nettsiden:  
<https://scansorlie.no/produkt/up2272-up-easy-to-go-understell/>

